

SMART-B1640III

birth coupling of servo turret
伺服刀塔用三片式離合齒

Material	工件材質	SCM415
Hardness	工件硬度	HRC56-60
Material Size	工件尺寸	Ø210x50(H)mm
Machining Time	加工時間	42min / 42分



Point of Requirement 需求重點

12

It takes you only 10 mins to manage to use profile dressing and to form grinding by SMART grinders with professional program and fixture.
成型輪廓修整之速成與專用程式與治具

Point of Requirement / 需求重點	Specifications or Accuracy / 規格或精度
Grinding Wheel / 砂輪型式	32A-80-J-9-V (Brand:Kinik Taiwan)
Indexing Accuracy / 旋轉精度	±4" (±4秒)
Repeat Indexing Accuracy / 重複旋轉精度	±1" (±1秒)

12. hirth coupling of servo turret / 伺服刀塔用三片式離合齒

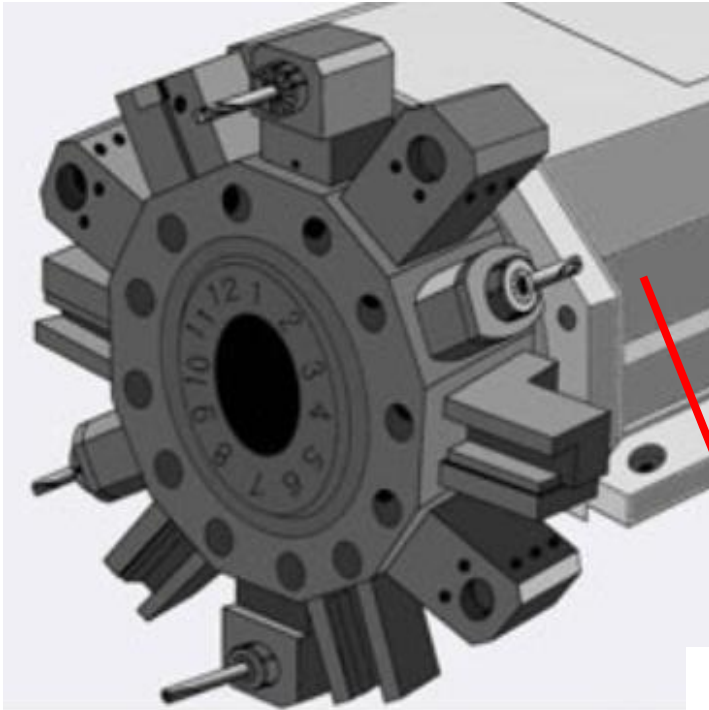

servo turret
伺服刀塔

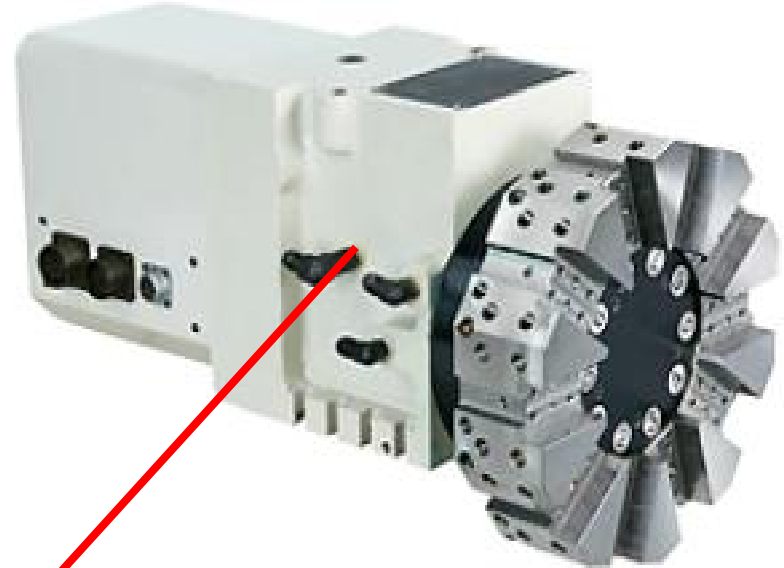

hirth coupling
離合齒

12. hirth coupling of servo turret / 伺服刀塔用三片式離合齒

Main accuracy
主要要求精度

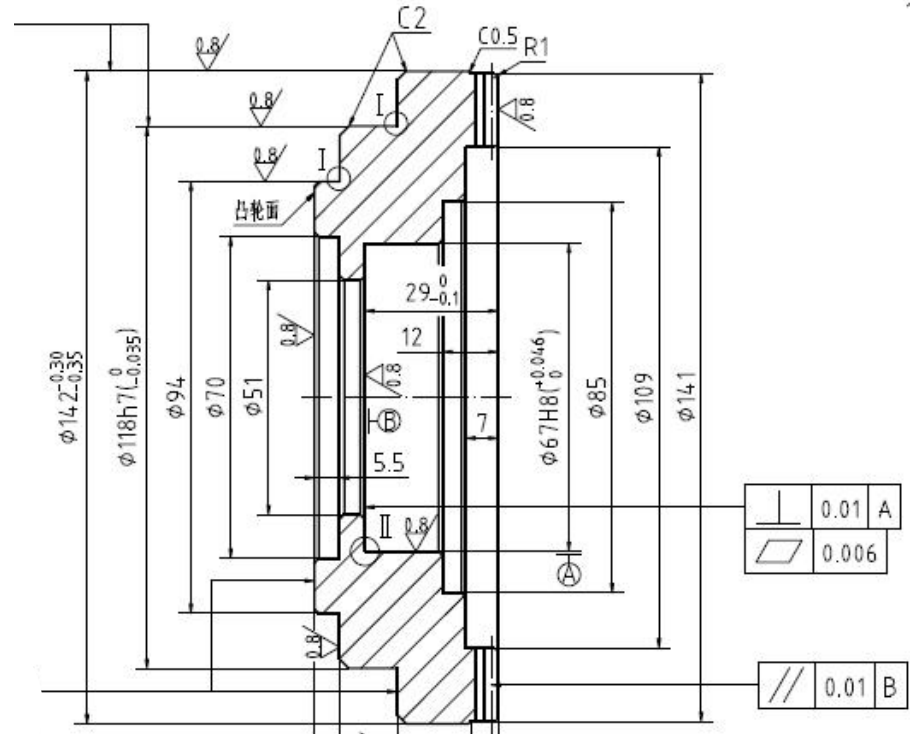
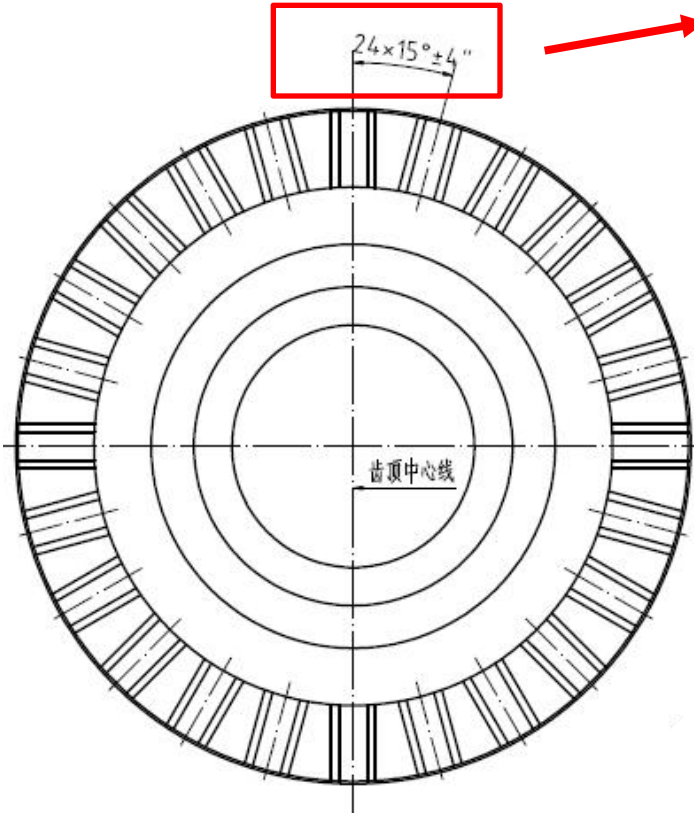

12. hirth coupling of servo turret / 伺服刀塔用三片式離合齒

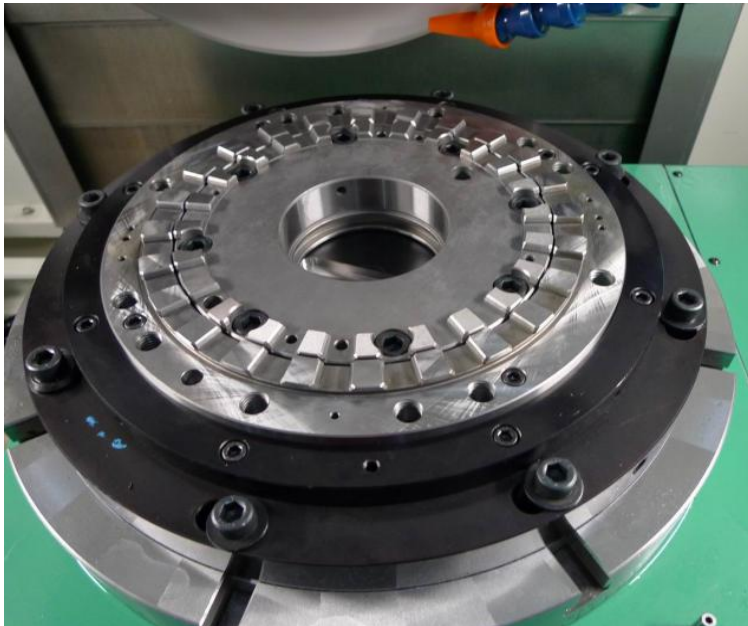

05. hirth coupling of servo turret / 伺服刀塔用三片式離合齒

